

# 47-53 Chevy Stepside Drill-In Kit



(8) Round Head  
1" Screws  
(Front Tabs)



(4) Self Tappers  
(Strikers)



(2) Type Two Drill In Front Bracket-Female

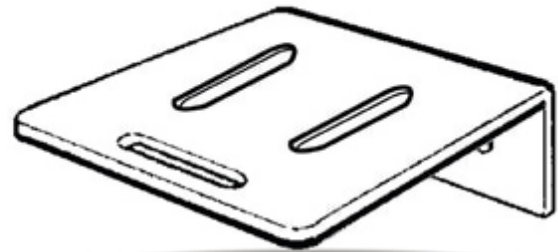

Dual Locks and Keys (2)

(2) 27" 80 lbs Shock



Striker Bracket

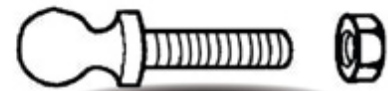

2 Threaded Shock Balls  
2 Hex Nuts

Page 1

**WARNING:** If you are not familiar with the use of hand tools or are not accustomed to working on motor vehicles, have a dealer or accessory shop install the Kustom Lid. Carefully read all the instructions prior to attempting to fit the Lid. Before fitting the Lid, park the vehicle on level ground in a well lit area and apply the emergency brake. After installation, check that the Lid works correctly and securely locks shut. Periodically check all fasteners for tightness. Retighten only the loose fasteners. When using power or hand tools, always wear the correct protective clothing recommended by the tool manufacturer.



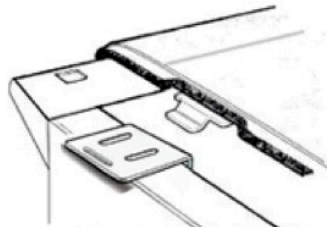

Approx. Bracket Location Shown -Remove it Prior to Marking Bed-

### Marking The Location of The Front Tabs

- Set the lid on the truck, with the tailgate closed square it up on the bed to your preferences.
- Using a china marker, draw the location of the front tabs onto the truck bed.
- Scoot the lid back, and carefully drill in the tab. We suggest drill in the top screws first, nice and snug, set the lid on, lift it up to drop it into the hinges, if you like the fitment of the lid take it back off and finish the rest of the screws.

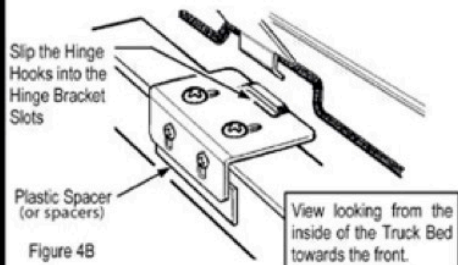

### Hooking The Lid

- With the help of two buddies one on each side at the front, lift the lid up from the rear and hook it into the female slots.
- Greasing up the tabs and cycling it up and down a few times insures proper movement of the tabs.
- If the lid is too tight at the rear, insert the plastic spacers provided in the kit. try to keep the same number on each side. The lid should be about 3/8" from the tailgate.

### Shock Mounts Into Top Hole

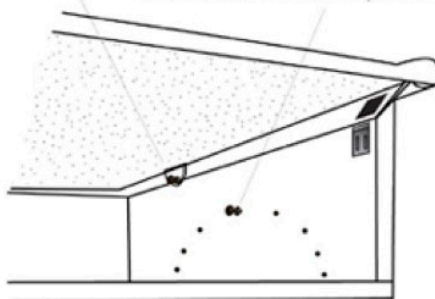

### Shock Mounts

- Counting from the back use the 5th fender bolt to mount the shock mount. You will need to tighten it up from the inside of the fender.
- You may now hook the shocks up, the thicker end of the shock will be the top.

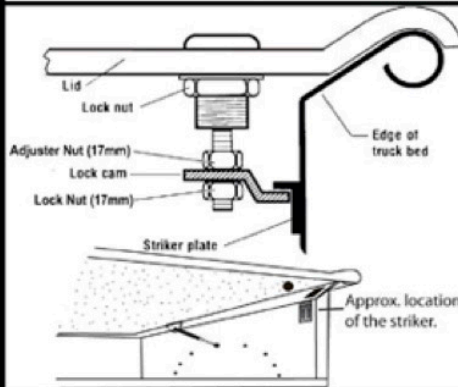

### Drilling Striker Bracket Into Bedside

- Once the lid is installed properly you must now install the strikers. Assemble the lock as shown and use it to determine the best place to mount the striker. Normally its at the top of the bed side. The one in the illustration to the left is slightly lower then the new style strikers.
- Your finished! Enjoy your beautiful new Gaylords lid and please periodically check the hardware to ensure everything stays tight