

INSTRUCTIONS

1" to 3" Lowering Block Instructions (Read and understand before starting)

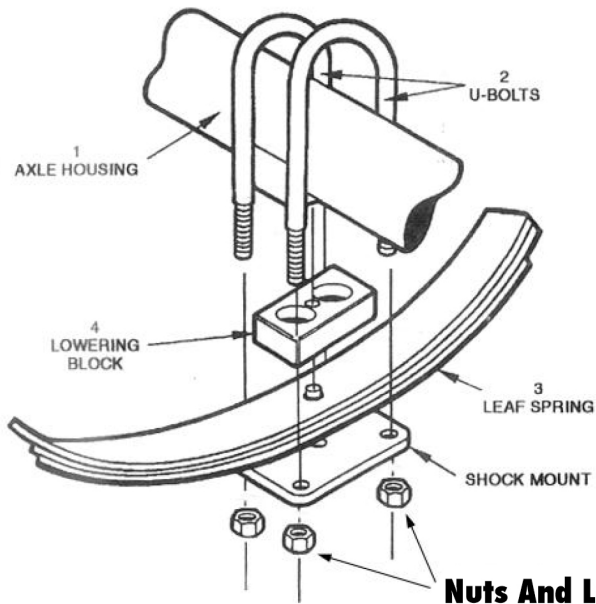

STEP 1 IMPORTANT

Jack up vehicle and place jack stand under frame nearest front or rear area being worked on. Jack stand should be positioned so vehicle does not fall.

STEP II

Doing one side at a time, remove the U-Bolts, Item 2.

Using a hydraulic hand jack, raise axle, item 1 from spring, Item 3.

Carefully insert lowering block or blocks, Item 4, between axle housing, Item 1, and the leaf spring, Item 3.

Lower axle, Item 1, down so weight is on lowering blocks, Item 4, and install and tighten U-Bolts, Item 2, to a torque rating of 80 pounds.

Repeat this procedure on the other side of the vehicle.

It is recommended to make a habit of retightening the bolts every 6 months.